

面向自主泊车任务的视觉感知与建图定位

张林
同济大学软件学院

Fall 2024



提纲

- 背景概述
- 环视系统离线标定与在线位姿修正
- 停车位检测与定位
- VIS_{SLAM} : 面向室内自主泊车任务的SLAM系统
- 总结与展望



背景概述

环境感知系统



毫米波雷达+前视相机+环视相机

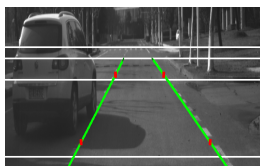

车道线检测

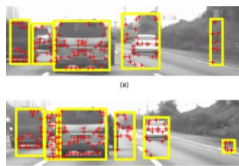

车辆及行人检测



交通标识检测

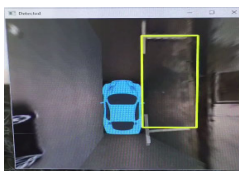

库位线检测

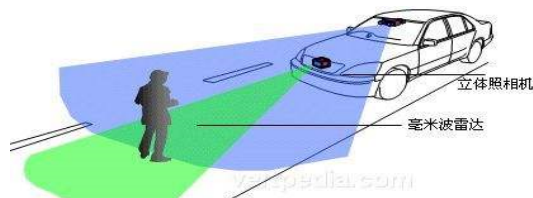

多源传感器信息融合

中央决策系统



中央决策控制器

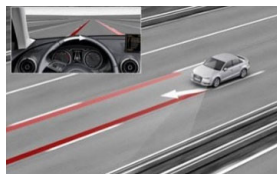

车道保持

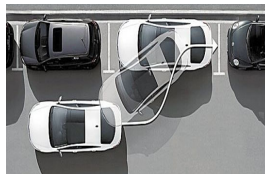

自动泊车



前向防撞

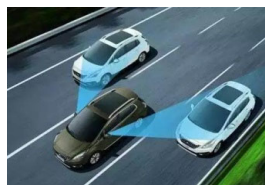

变道辅助

底层控制系统



驱/制动控制



转向控制



挡位控制



车身控制



背景概述

人工智能

	自动驾驶	自主泊车
边界	整个出行路程	出行的最后一公里
特点	各种行驶环境	停车场环境

感知

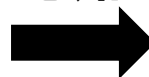

露天环境：

- GPS信号

室内泊车环境：

- 无GPS信号，依赖自身搭载的传感器
- 对车辆进行定位，并建立语义地图

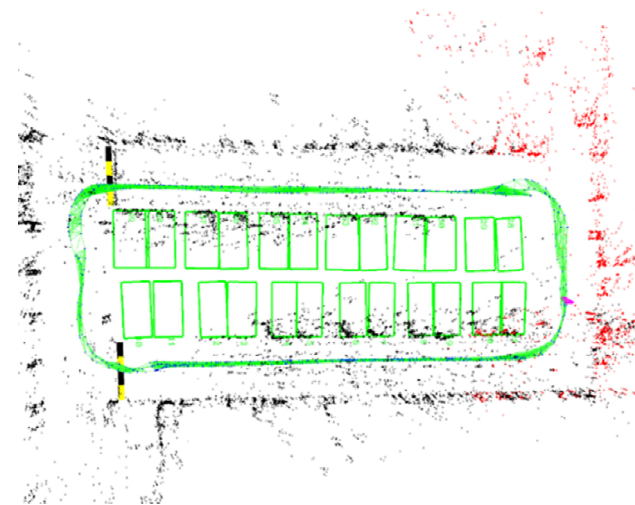

□ 本课题组从2017年开展相关工作

- ✓ 国家自然科学基金面上项目“面向室内环境自主泊车任务的定位与建图关键技术研究”
- ✓ 国家自然科学基金面上项目“基于视觉的停车位检测技术中关键问题的研究”
- ✓ 上海市科学技术委员会高新技术领域项目，面向“最后一公里”的智能驾驶关键理论及应用
- ✓ 华为技术有限公司项目“环视停车位检测系统及其关键技术研究”
- ✓ 上汽集团项目“短程自主泊车系统开发”



背景概述



多源传感器融合可利用多个廉价传感器采集的数据，求解获得高精度结果



背景概述—总体目标

- 在缺乏GPS信号的室内泊车环境中，利用自身搭载的多源传感器建立室内泊车场景的语义地图

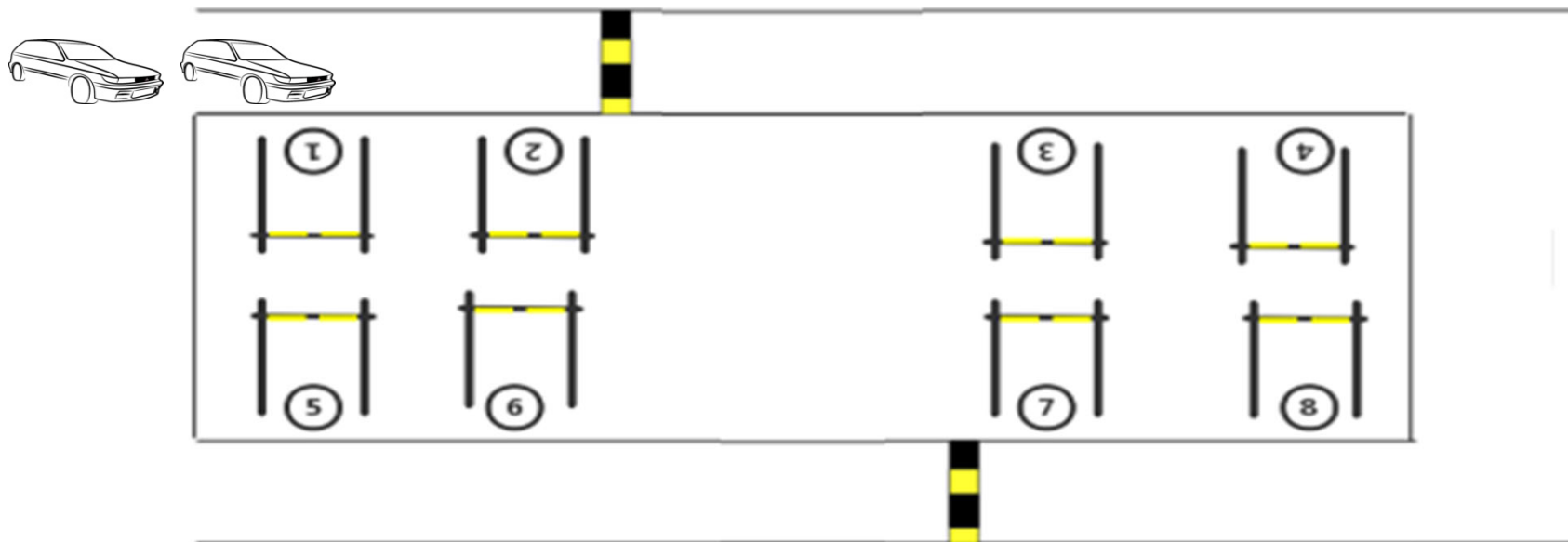

室内泊车场景的语义地图的最终效果图



背景概述—总体目标

□ 语义感知模块：

- ✓ 基于深度学习的语义目标检测
- ✓ 训练数据的收集与仿真

□ 定位与建图模块：

- ✓ 在未知环境中依靠系统自身携带传感器，完成定位与环境地图构建

构建室内泊车环境的语义地图





提纲

- 背景概述
- 环视系统离线标定与在线位姿修正
- 停车位检测与定位
- VIS_{SLAM} : 面向室内自主泊车任务的SLAM系统
- 总结与展望



环视系统离线标定



车载环视

鱼眼图像

离线标定

实时环视图

- 典型的环视系统由四至六个广角鱼眼相机组成，这些鱼眼相机能够拍摄到车辆前后左右四个方向的视图
- 通过离线标定技术，标定相机的外参，从而拼接形成无缝的环视图



环视系统离线标定

- The surround-view is composed of the four bird's-eye views (front, left, back, and right)
- To get the bird's-eye view, the essence is generating a look-up table mapping a point on bird's-eye view to a point on the fish-eye image
 - Decide the similarity transformation matrix $P_{B \rightarrow W}$, mapping a point from the bird's-eye view coordinate system to the world coordinate system
 - Decide the projective transformation matrix $P_{W \rightarrow U}$, mapping a point from the world coordinate system to the undistorted image coordinate system
 - Decide the look-up table $T_{U \rightarrow F}$, mapping a point from the undistorted image coordinate system to the fish-eye image coordinate system



环视系统离线标定

- 鸟瞰视图生成流程

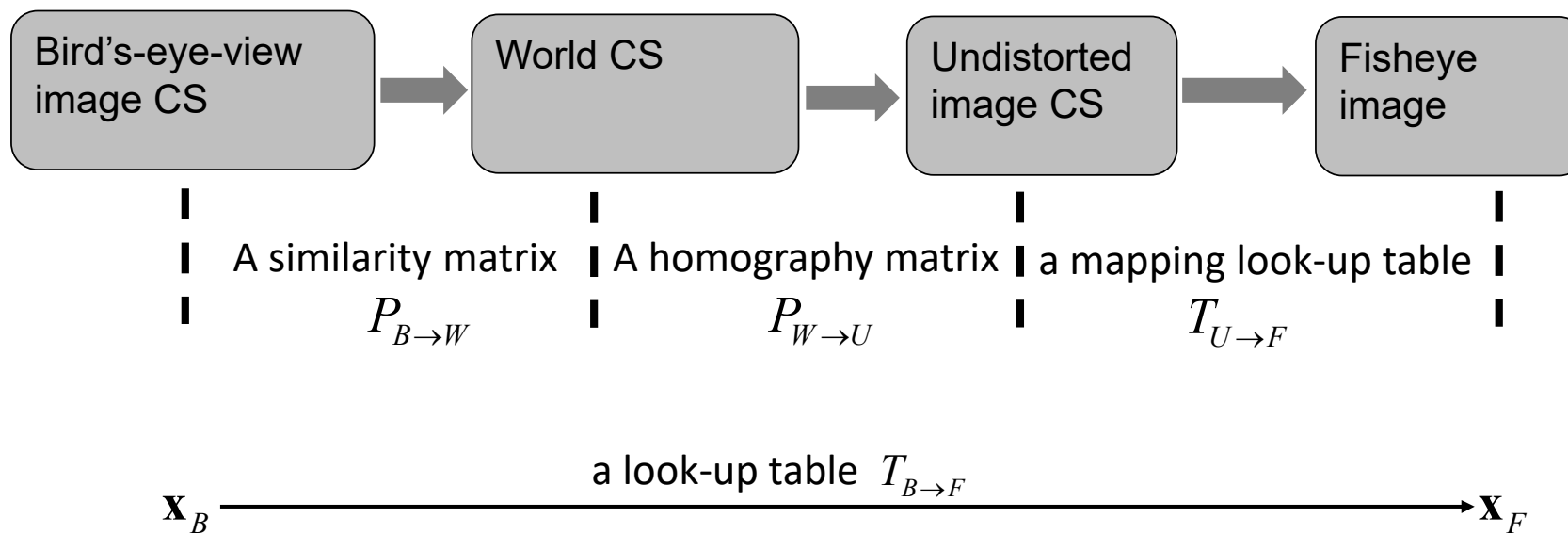



环视系统离线标定

- 鸟瞰视图生成流程
 - Distortion coefficients of a fish-eye camera and also the mapping look-up table $T_{U \rightarrow F}$ can be determined by the calibration routines provided in openCV



fisheye image



undistorted image



环视系统离线标定

- 鸟瞰视图生成流程
 - Determine $P_{W \rightarrow U}$

The physical plane (in WCS) and the undistorted image plane can be linked via a homography matrix $P_{W \rightarrow U}$

$$\mathbf{x}_U = P_{W \rightarrow U} \mathbf{x}_W$$

If we know a set of correspondence pairs $\{\mathbf{x}_{Ui}, \mathbf{x}_{Wi}\}_{i=1}^N$, $P_{W \rightarrow U}$ can be estimated using the least-square method



环视系统离线标定

- 鸟瞰视图生成流程

- Determine $P_{W \rightarrow U}$

A set of point correspondence pairs; for each pair, we know its coordinate on the undistorted image plane and its coordinate in the WCS

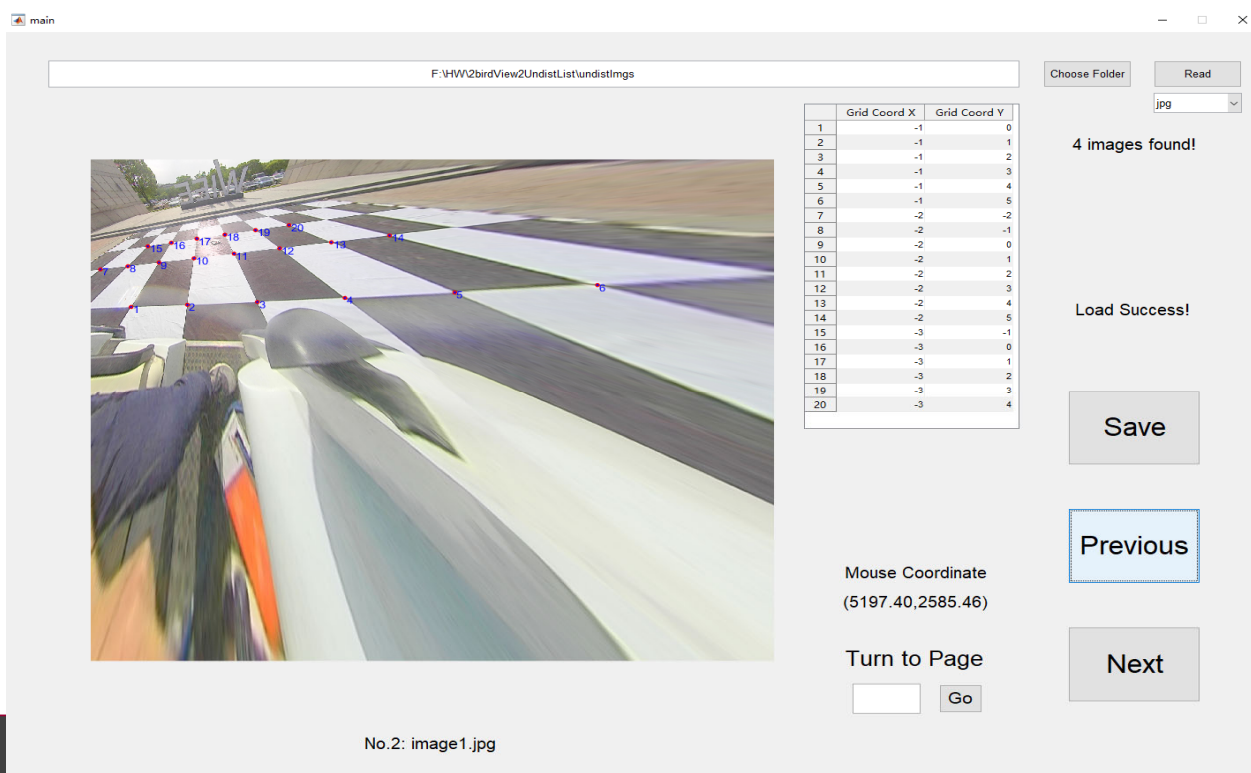



环视系统离线标定

示例

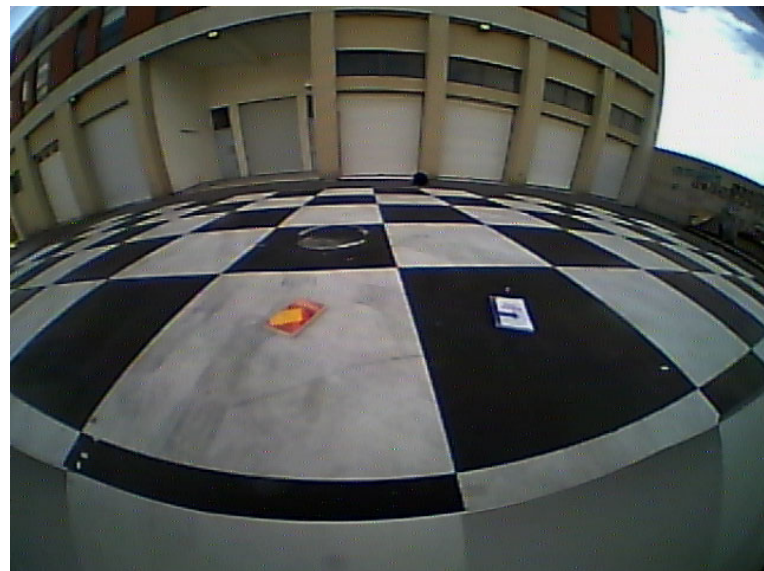

原始鱼眼图像

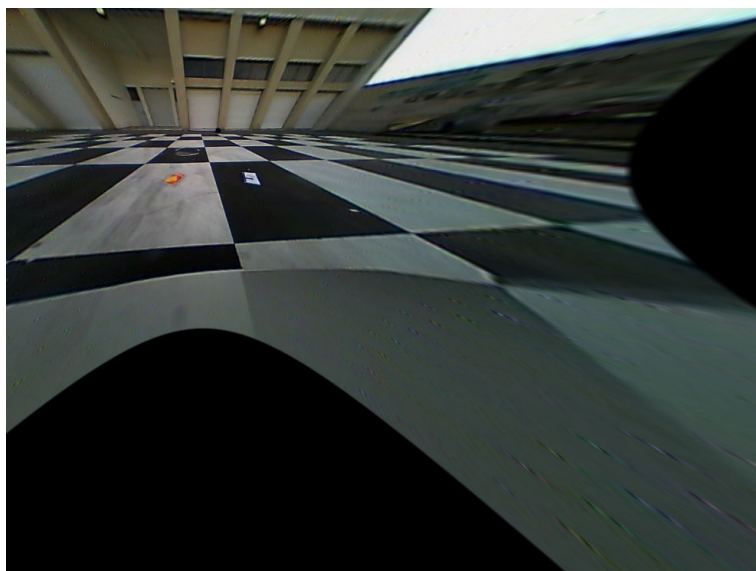

去畸变图像

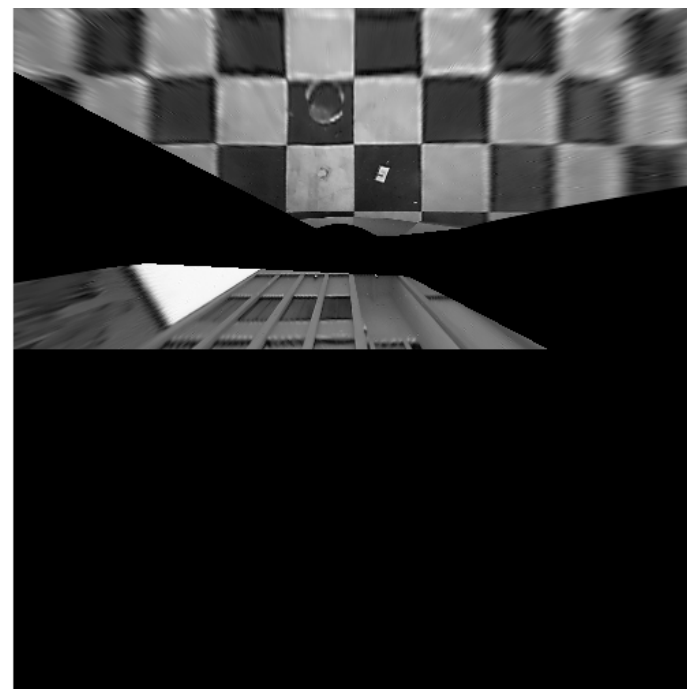

鸟瞰视图图像



环视系统离线标定



(a)



(b)



(c)



(d)

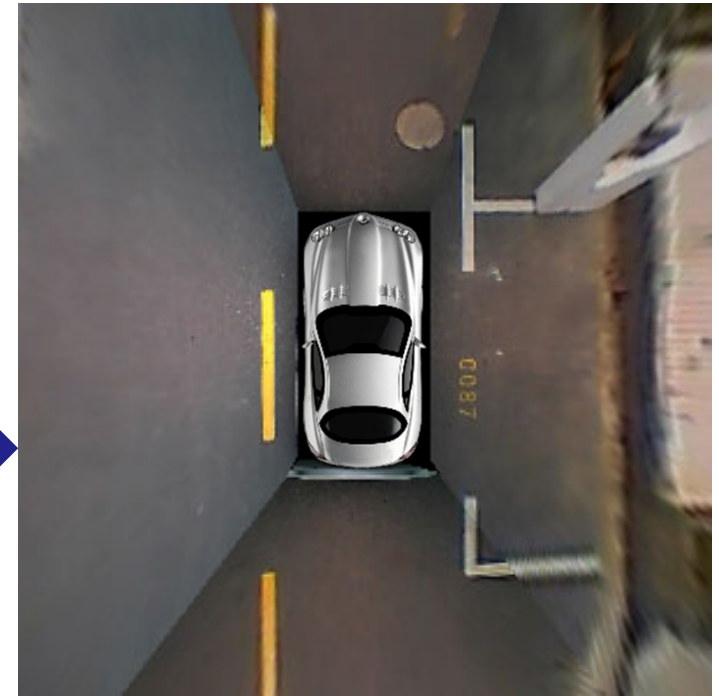

(e)

Image is of the size 600×600
 $\Leftrightarrow 10m \times 10m$ physical region



环视系统离线标定

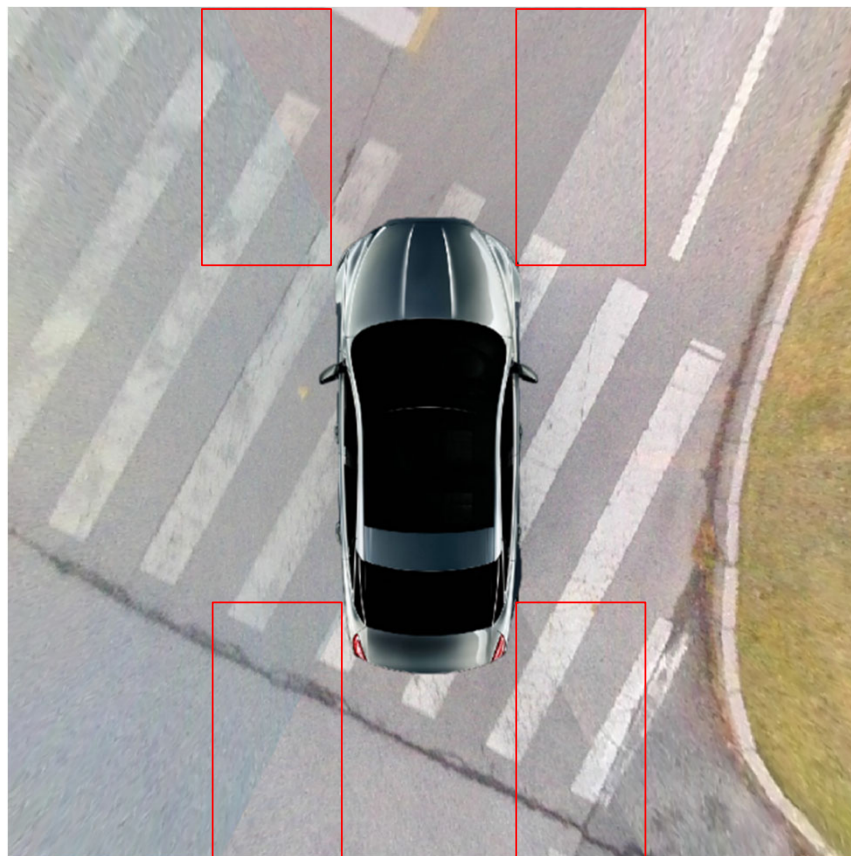

由于四个相机光照条件不同，环视图会存在明显的缝合线



光度对齐



环视系统离线标定

$$\begin{matrix} & & & & A \\ & & & & \uparrow \\ \begin{pmatrix} m_{FL_F} & -m_{FL_L} & 0 & 0 \\ 0 & m_{LB_L} & -m_{LB_B} & 0 \\ 0 & 0 & m_{BR_B} & -m_{BR_R} \\ -m_{RF_F} & 0 & 0 & m_{RF_R} \end{pmatrix} & \begin{pmatrix} r_F \\ r_L \\ r_B \\ r_R \end{pmatrix} & = & 0 & \longrightarrow \end{matrix}$$

Photometric coefficient

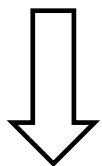

Homogeneous linear least square problem

$$\begin{cases} \mathbf{A}^T \mathbf{A} \mathbf{x} = \lambda \mathbf{x} \\ E(\mathbf{x}) = \|\mathbf{A} \mathbf{x}\|_2^2 = \mathbf{x}^T \mathbf{A}^T \mathbf{A} \mathbf{x} = \lambda \end{cases}$$

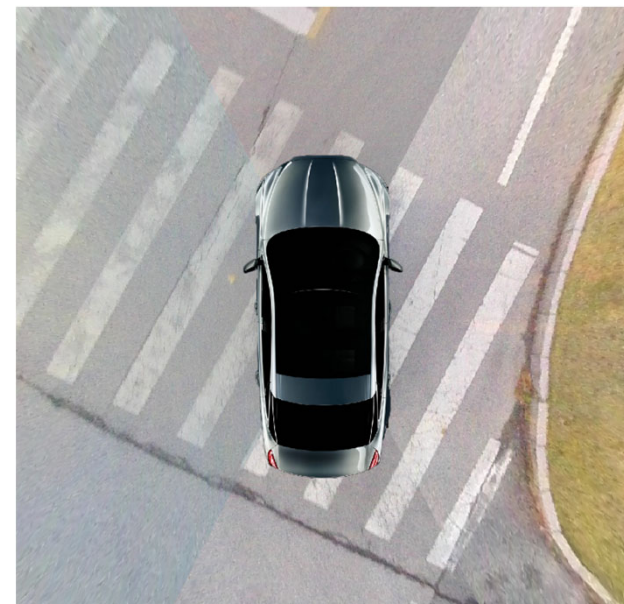

Adjust 4 areas in different channels separately according to the photometric coefficient



环视系统离线标定

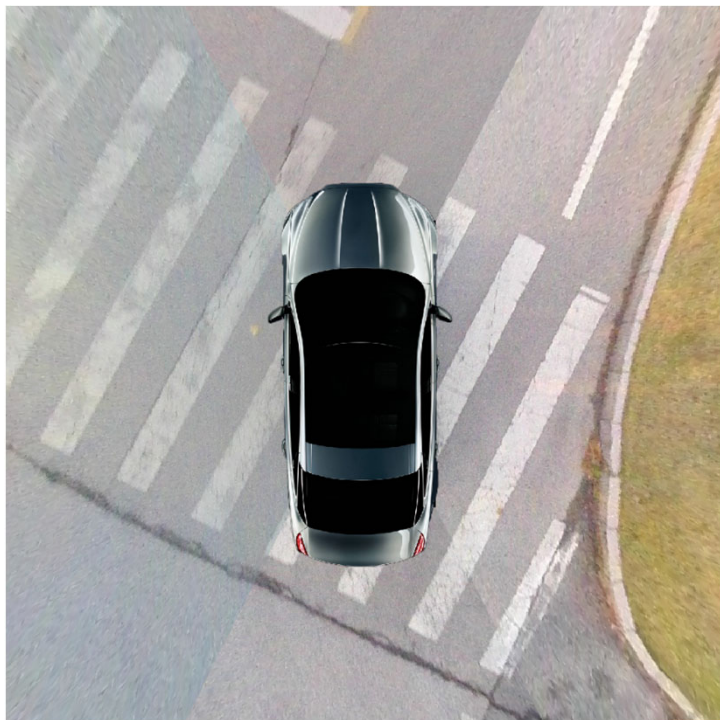

光度对齐之前

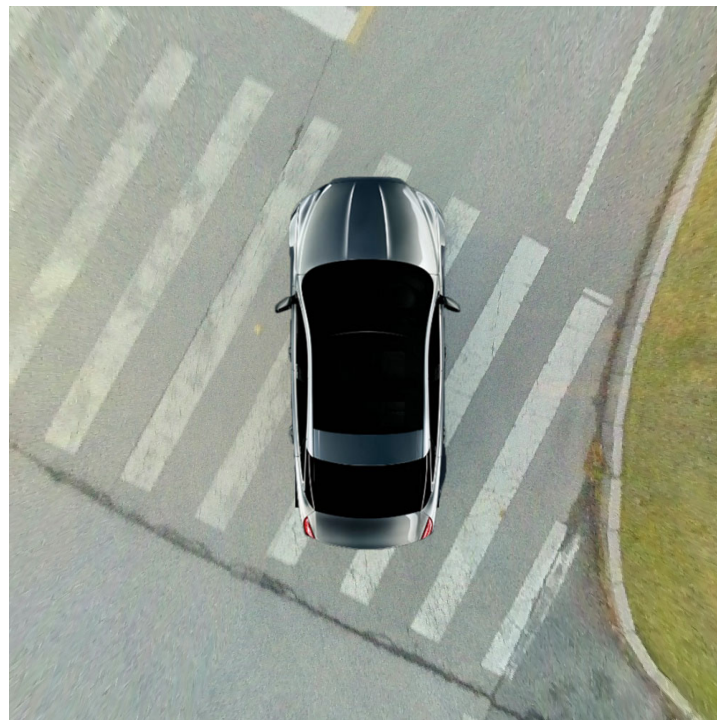

光度对齐之后



环视系统离线标定

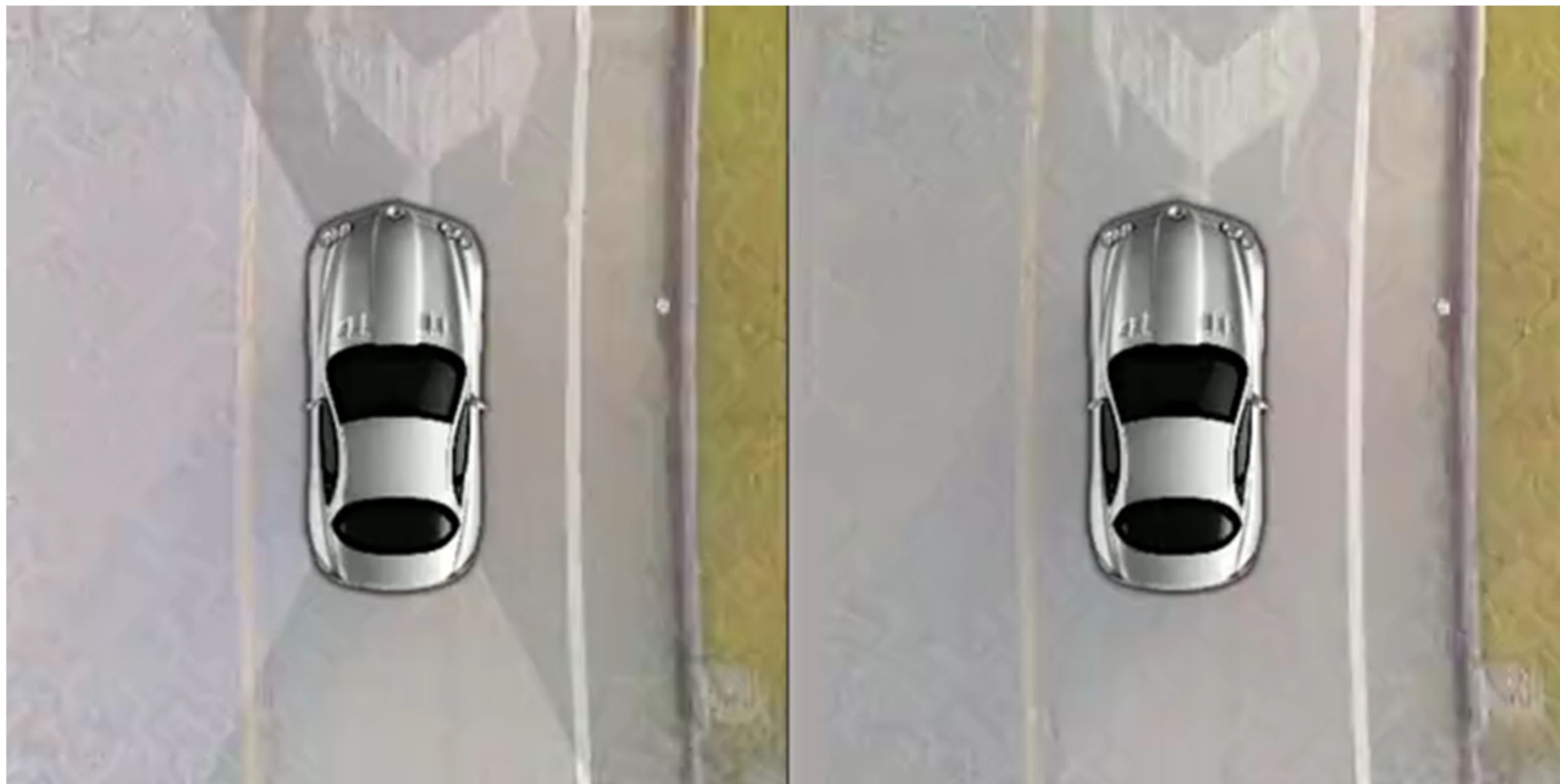



环视系统在线位姿修正

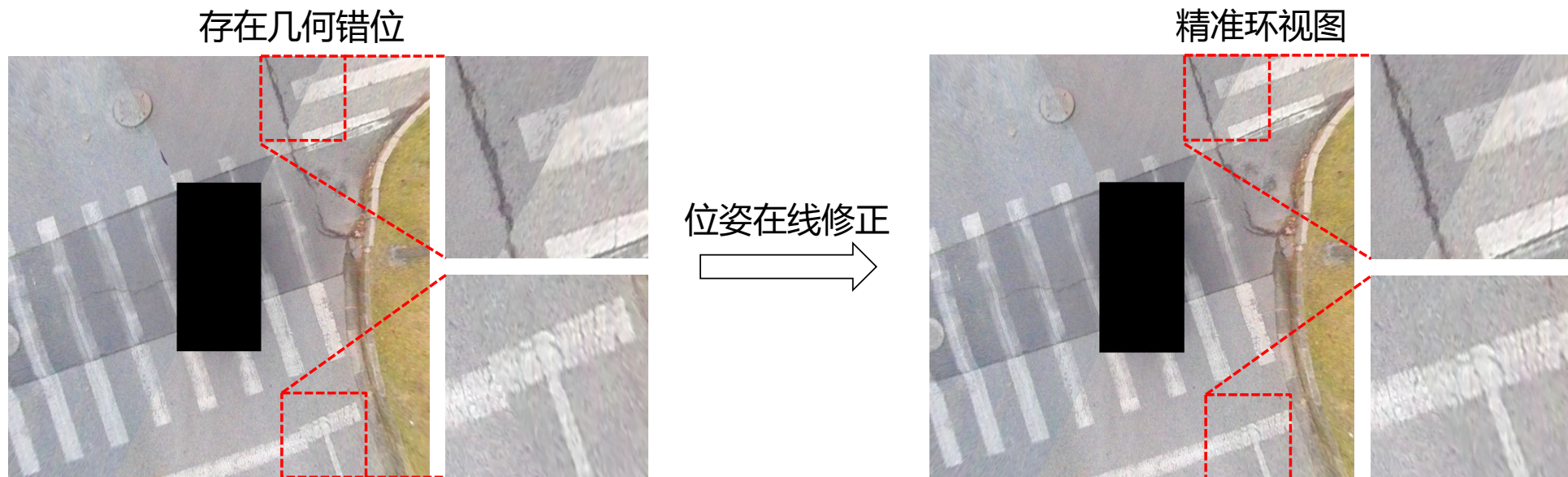

- 当汽车行驶过程中发生碰撞，颠簸，或是车辆胎压发生改变时，环视系统的相机位姿将发生变化。此时，如果不对系统外参数进行相应的修正，拼接生成的环视图中将出现明显的几何错位
- 基于在线修正技术，在车辆行驶过程中，环视系统外参数将自动被校正，环视图中的几何错位也将被消除



环视系统在线位姿修正

- 我们提出的方法基于稀疏直接法，使用光度误差而非重投影误差作为损失。不依赖特征匹配，轻量而有效，仅仅依靠一张环视图，即可在线完成相机位姿修正

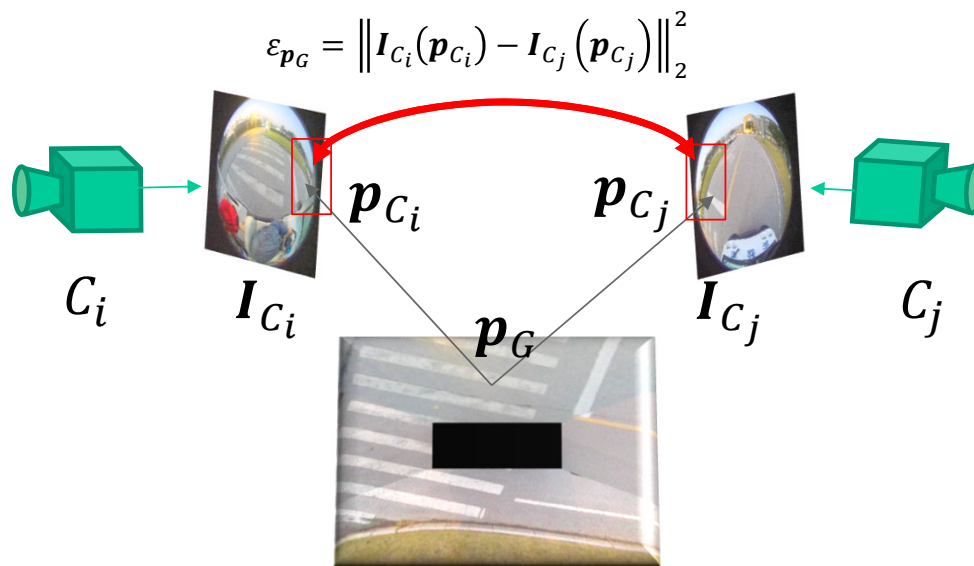

光度误差模型



环视系统在线位姿修正

- 基于链式法则与灰度不变近似对损失项进行求导并优化

$$\frac{\partial \varepsilon_{p_G}}{\partial \xi_{C_i}} = \frac{\partial \varepsilon_{p_G}}{\partial I_{C_i}} \frac{\partial I_{C_i}}{\partial p_{C_i}} \frac{\partial p_{C_i}}{\partial P_{C_i}} \frac{\partial P_{C_i}}{\partial \xi_{C_i}}$$

图像灰度梯度

与相机内参相关

与三维点位置相关

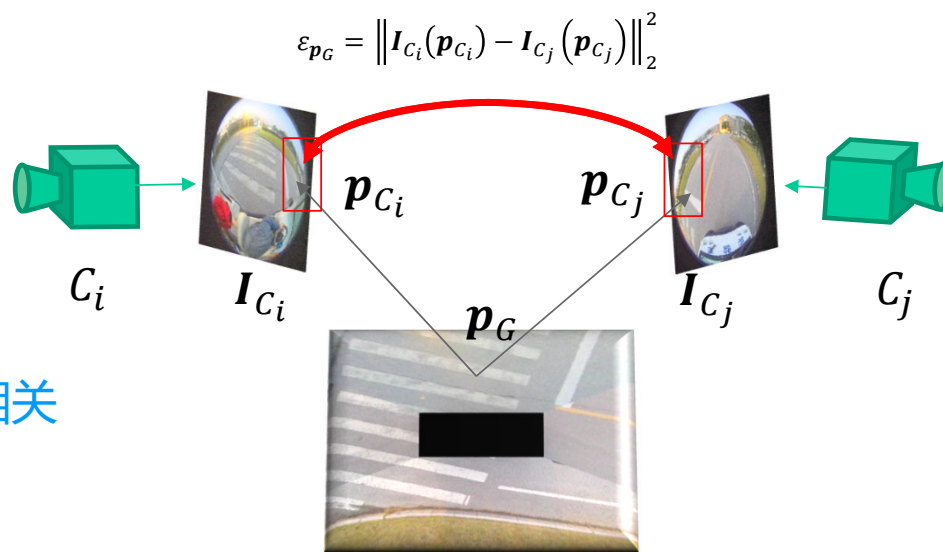



环视系统在线位姿修正

- 基于链式法则与灰度不变近似对损失项进行求导并优化

$$\frac{\partial \varepsilon_{p_G}}{\partial \xi_{C_i}} = \frac{\partial \varepsilon_{p_G}}{\partial I_{C_i}} \frac{\partial I_{C_i}}{\partial p_{C_i}} \frac{\partial p_{C_i}}{\partial P_{C_i}} \frac{\partial P_{C_i}}{\partial \xi_{C_i}}$$

- 最终误差关于相机位姿的导数可被表示为：

$$\frac{\partial \varepsilon_{p_G}}{\partial \xi_{C_i}} = \delta \cdot [\nabla I_{C_i}^{u_G} \quad \nabla I_{C_i}^{v_G}] \cdot \begin{bmatrix} \frac{f_x}{Z_{C_i}} & 0 & -\frac{f_x X_{C_i}}{Z_{C_i}^2} & -\frac{f_x X_{C_i} Y_{C_i}}{Z_{C_i}^2} & f_x + \frac{f_x X_{C_i}^2}{Z_{C_i}^2} & -\frac{f_y Y_{C_i}}{Z_{C_i}^2} \\ 0 & \frac{f_y}{Z_{C_i}} & -\frac{f_y Y_{C_i}}{Z_{C_i}^2} & -f_y - \frac{f_y Y_{C_i}^2}{Z_{C_i}^2} & \frac{f_y X_{C_i} Y_{C_i}}{Z_{C_i}^2} & \frac{f_y X_{C_i}}{Z_{C_i}} \end{bmatrix}$$

其中， δ 为光度差 $I_{C_i}(p_{C_i}) - I_{C_j}(p_{C_j})$



环视系统在线位姿修正

- 逐步优化相机位姿使光度误差最小化，最终可以获得精确的相机位姿

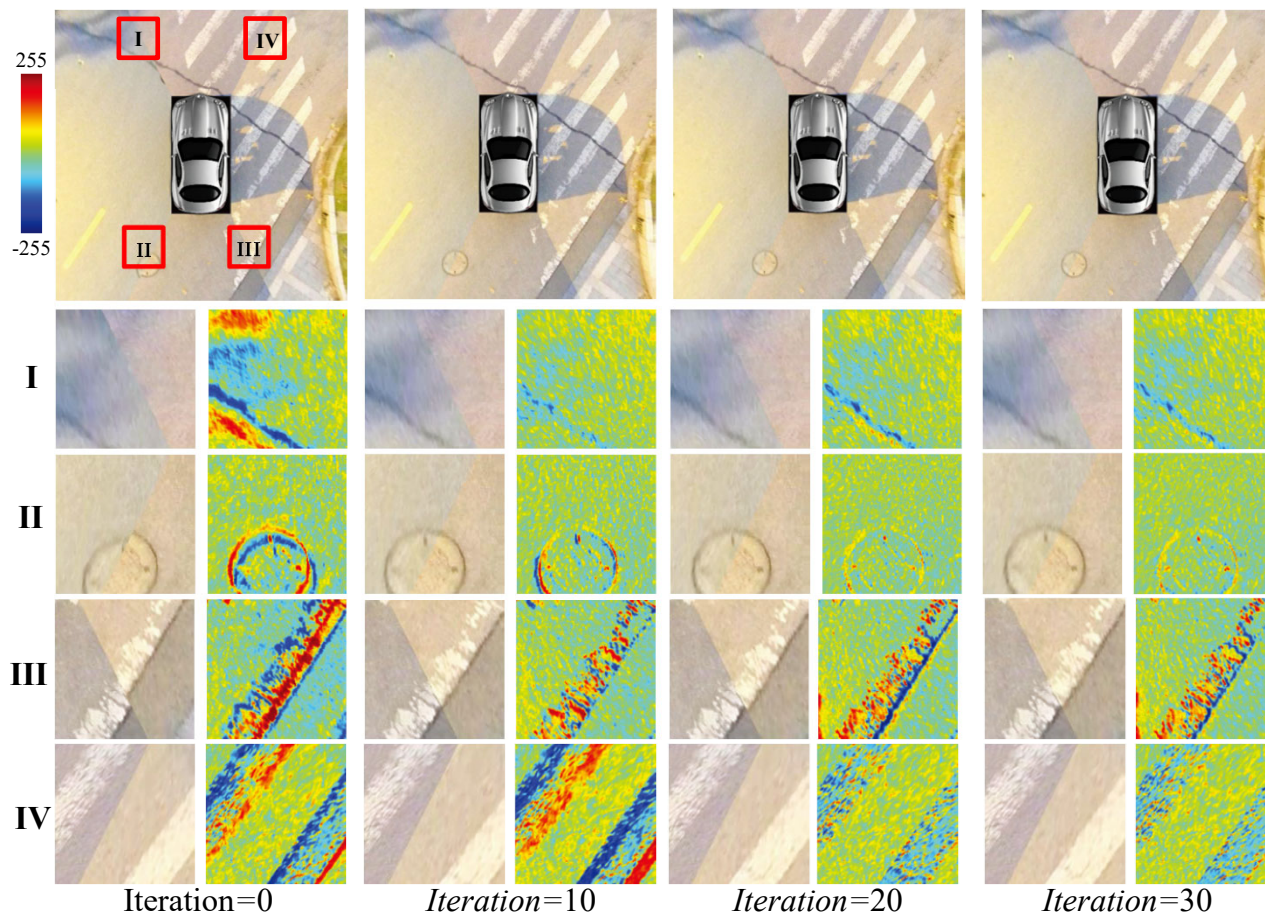



环视系统在线位姿修正

- 修正前后效果对比

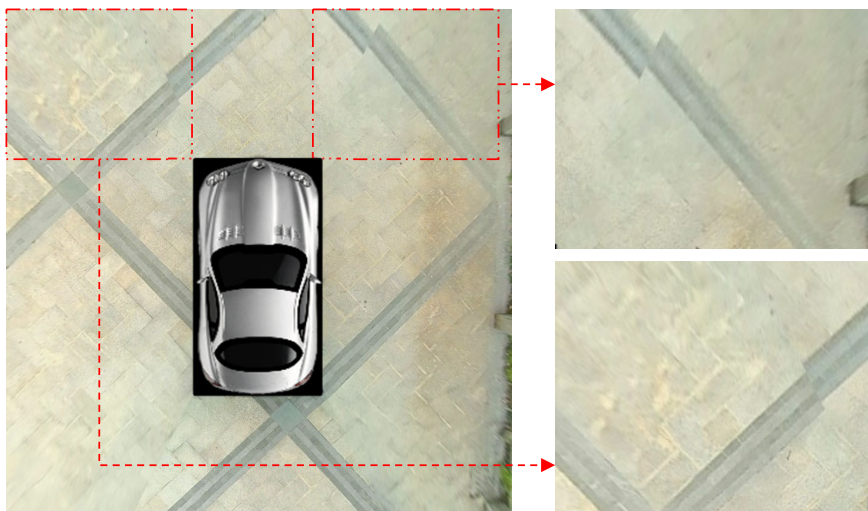

修正前

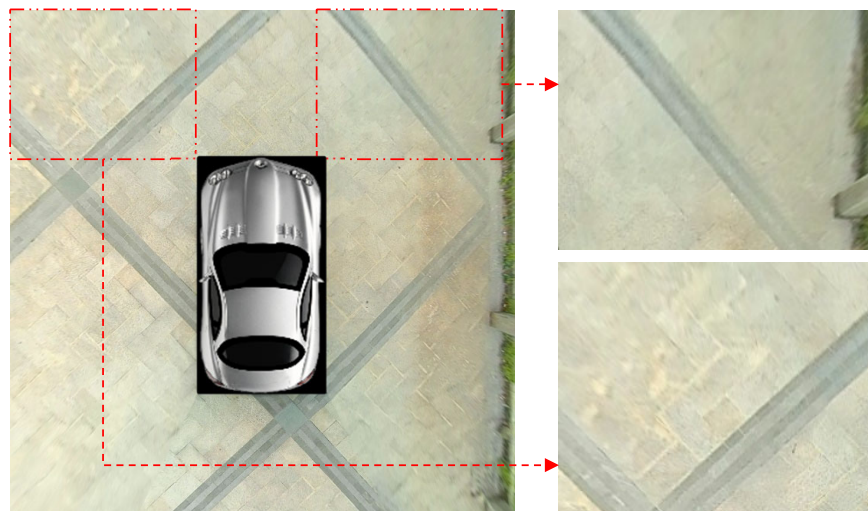

修正后



环视系统在线位姿修正

- 修正前后效果对比

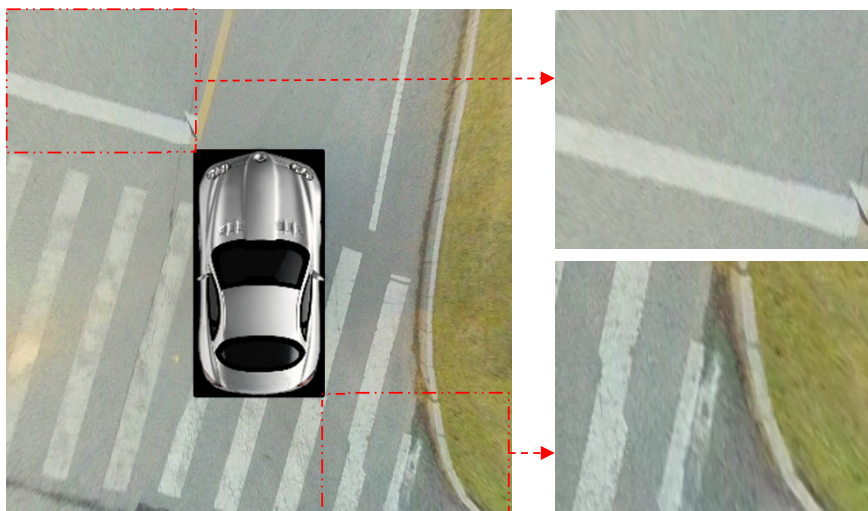

修正前

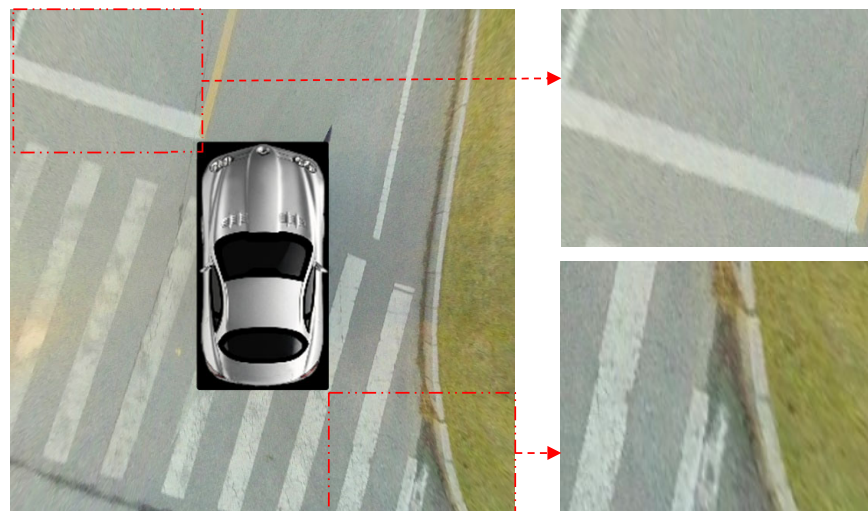

修正后



环视系统在线位姿修正

- 修正前后效果对比

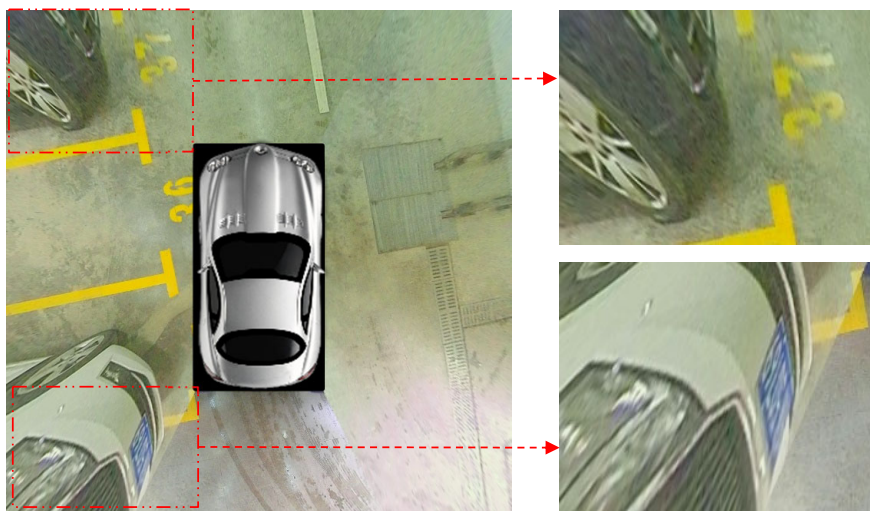

修正前

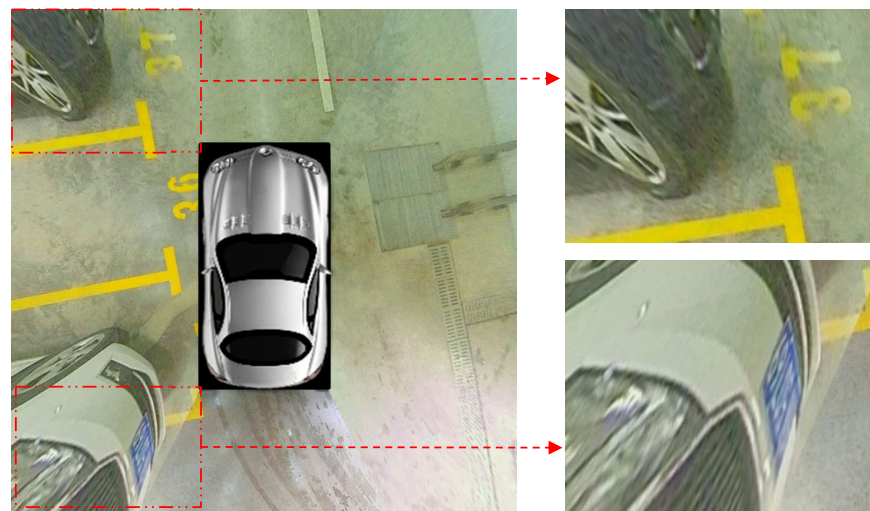

修正后



环视系统在线位姿修正

- 修正效果展示

**ROECS:
A Robust Semi-direct Pipeline Towards Online
Extrinsics Correction of the Surround-view System**

ACM MM 2021 Paper ID: 1640



提纲

- 背景概述
- 环视系统离线标定与在线位姿修正
- 停车位检测与定位
- **VIS_{SLAM}: 面向室内自主泊车任务的SLAM系统**
- 总结与展望



背景

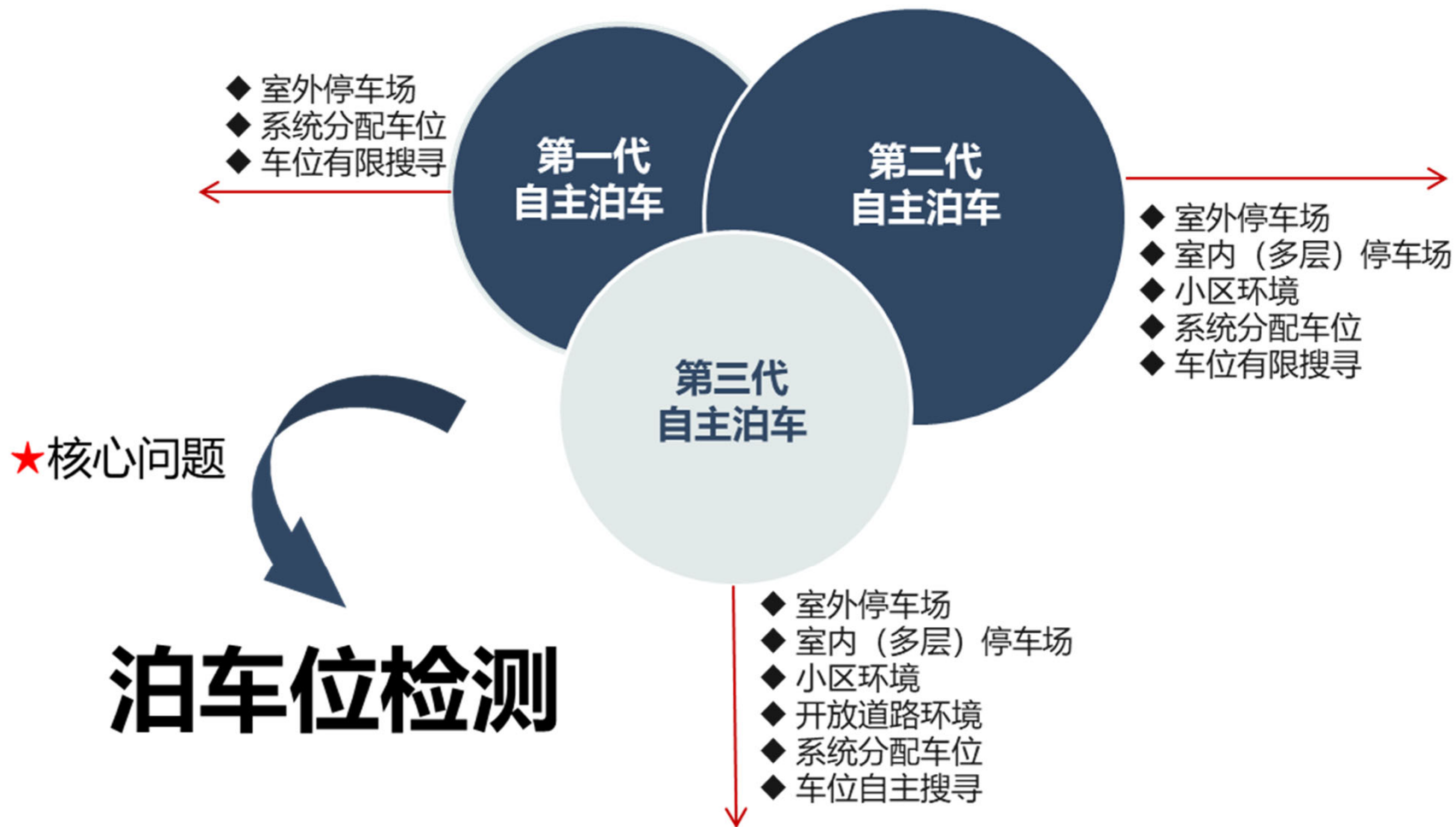



背景



如何检测到停车位并返回其在车辆坐标系下的坐标?



背景

- Infrastructure-based solutions
 - Need support from the parking site
 - Usually, the vehicle needs to communicate with the infrastructure





背景

- Infrastructure-based solutions
- On-vehicle-sensor based solutions
 - Parking-vacancy detection
 - Ultrasonic radar
 - Stereo-vision
 - Depth camera

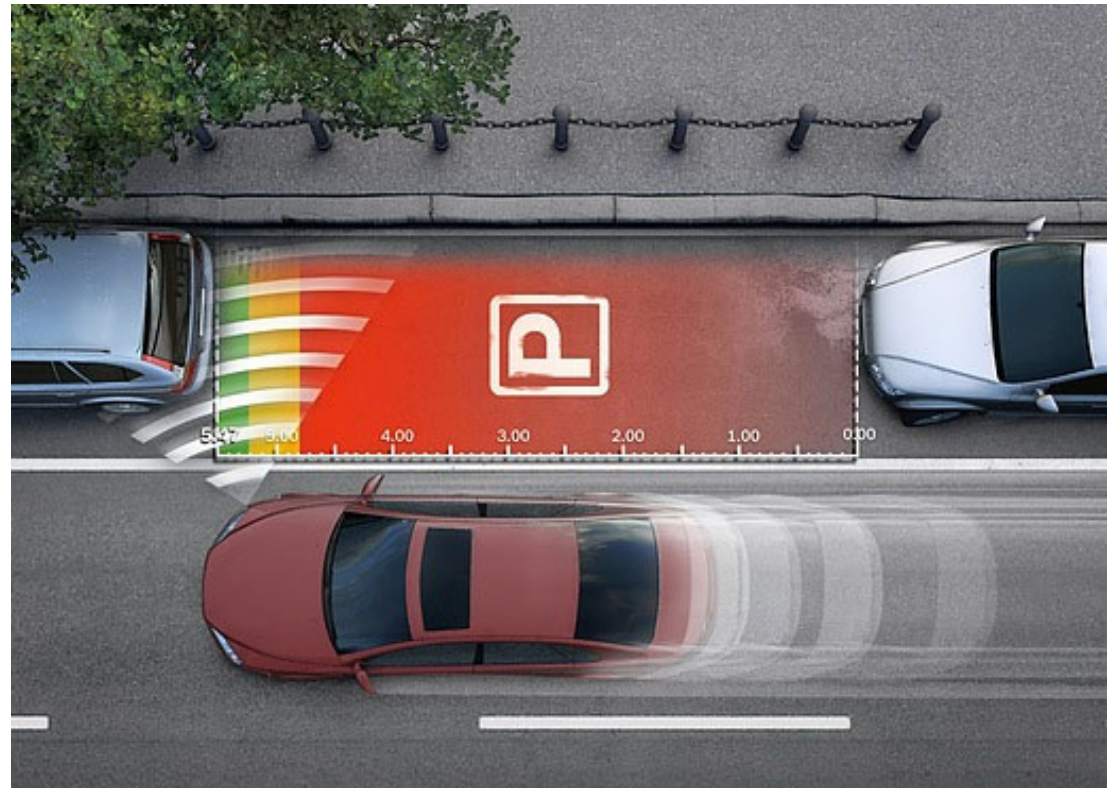



背景

- Infrastructure-based solutions
- On-vehicle-sensor based solutions
 - Parking-vacancy detection
 - Parking-slot (defined by lines, vision-based) detection **our focus**

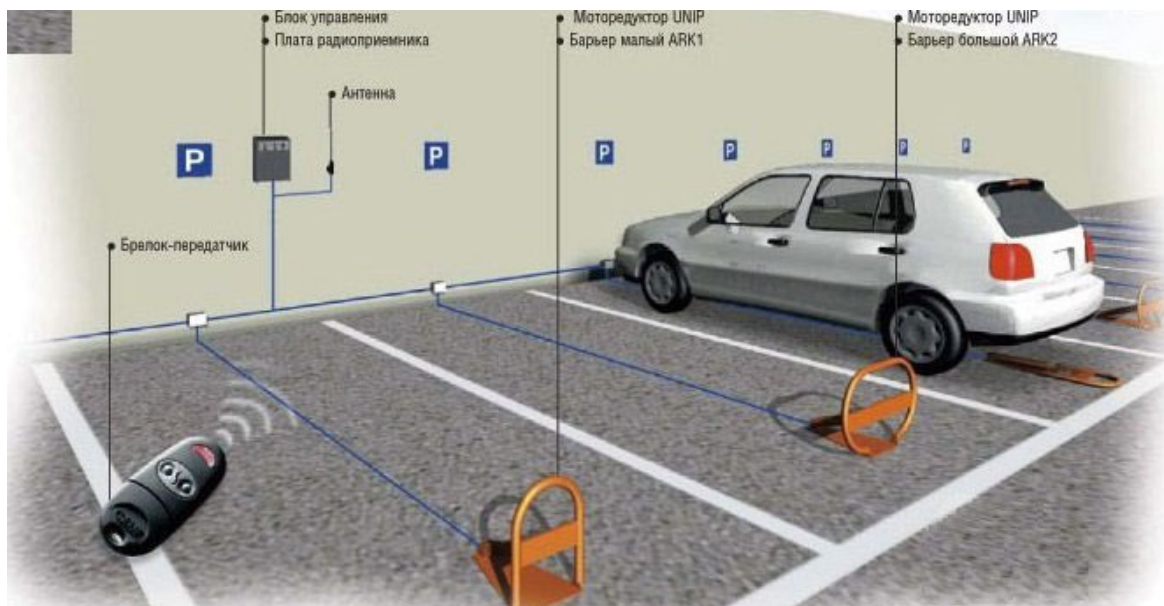



背景

- 研究现状的不足
 - 此领域没有公开数据集
 - 现有方法都是基于低层视觉特征的（边缘、角点、线等），鲁棒性和准确性都很有限
- 我们的贡献^[1,2]
 - ✓ 构建并公开了大规模带标注的环视图像数据集
 - ✓ 首次提出了基于机器学习理论的解决方案
 - ✓ 针对荣威E50车型开发实际系统并完成实车自主泊车系统验证

- ① Lin Zhang et al., "Vision-based parking-slot detection: A DCNN-based approach and a large-scale benchmark dataset", IEEE Trans. Image Processing, vol. 27, no. 11, pp. 5350-5364, 2018.
- ② Lin Zhang et al., "Vision-based parking-slot detection: A benchmark and a learning-based approach", Symmetry, vol. 10, no. 3, pp. 64:1-18, 2018.



总体流程

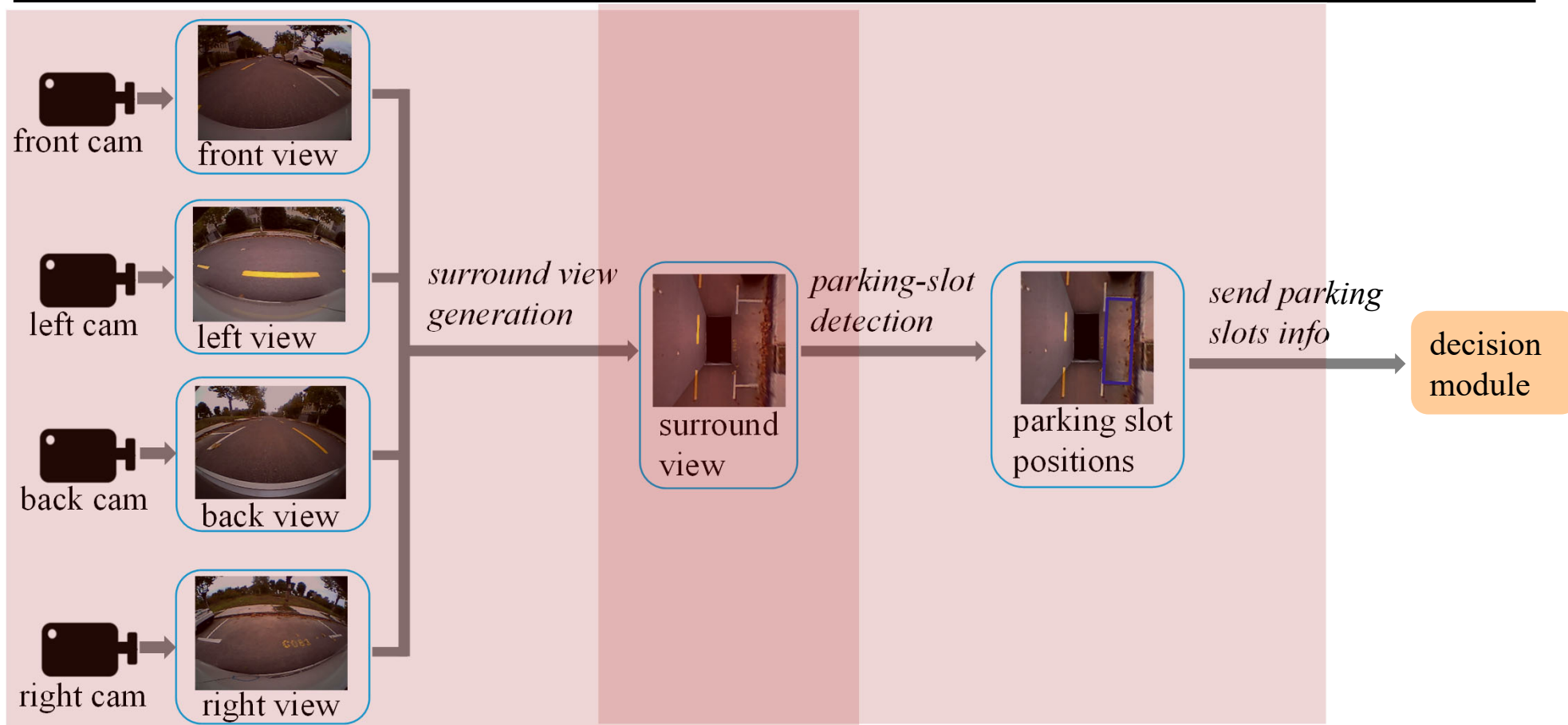

基于视觉的自主泊车系统工作流程



面临的挑战

- It is not an easy task due to the existence of
 - ✓ Various types of road textures
 - ✓ Various types of parking-slots
 - ✓ Illumination variation
 - ✓ Partially damaged parking-lines
 - ✓ Non-uniform shadow

Making the low-level vision based algorithms difficult to succeed



面临的挑战

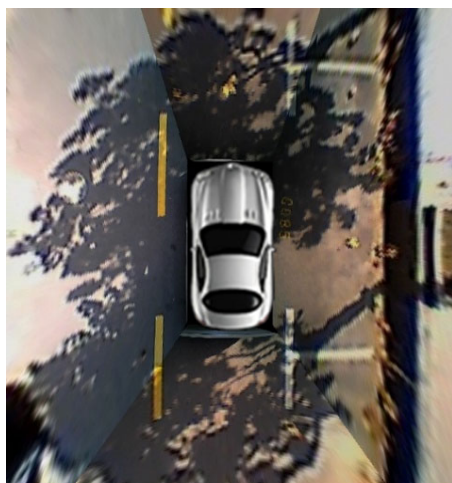
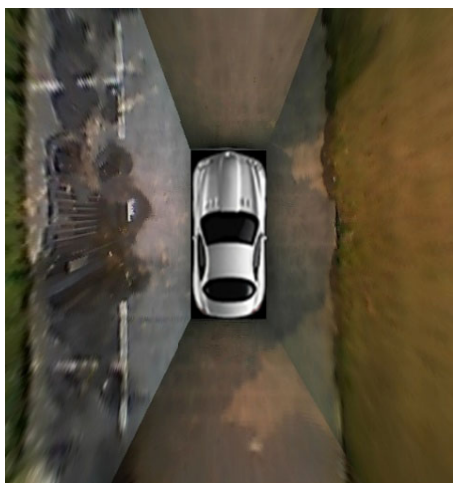
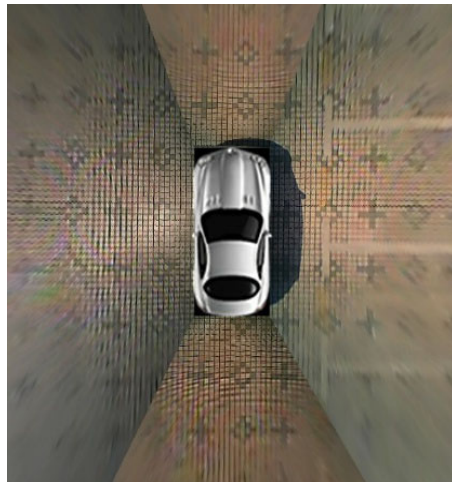
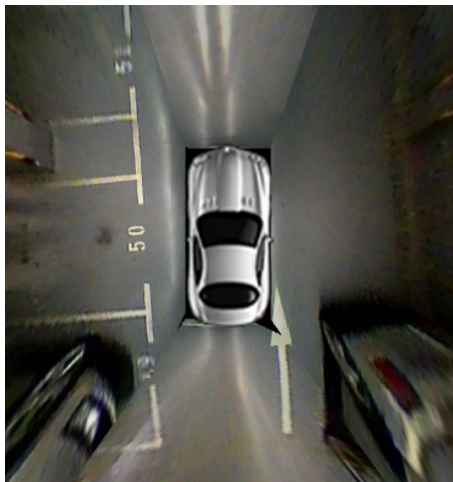



DeepPS: A DCNN-based Approach

- Motivation

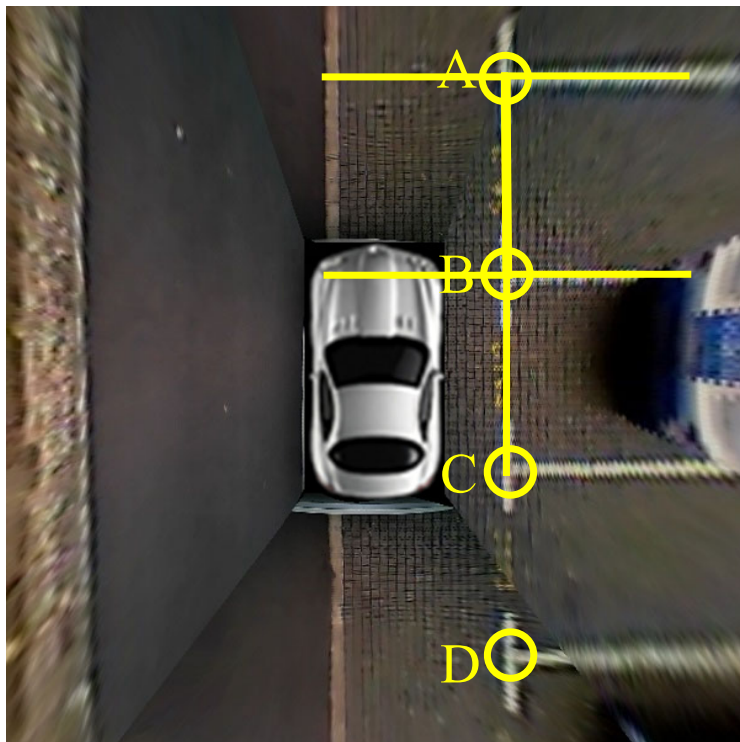

- ✓ Detect marking-points
- ✓ Decide the validity of entrance-lines and their types (can be solved as a classification problem)

Both of them can be solved by DCNN-based techniques



DeepPS: A DCNN-based Approach

- Marking-point detection by using a DCNN-based framework
 - We adopt YoloV2 as the detection framework
 - R-CNN (Region-based convolutional neural networks) (CVPR 2014)
 - SPPNet (Spatial Pyramid Pooling Network) (T-PAMI 2015)
 - Fast-RCNN (ICCV 2015)
 - Faster-RCNN (NIPS 2015)
 - Yolo (You Only Look Once) (CVPR 2016)
 - SSD (Single Shot Multibox Detector) (ECCV 1016)
 - Yolov2 (ArXiv 2016) *Accurate enough, fastest!*



DeepPS: A DCNN-based Approach

- Marking-point detection by using a DCNN-based framework
 - We adopt YoloV2 as the detection framework
 - Manually mark the positions of marking-points and define regions with fixed size centered at marking-points as “marking-point patterns”

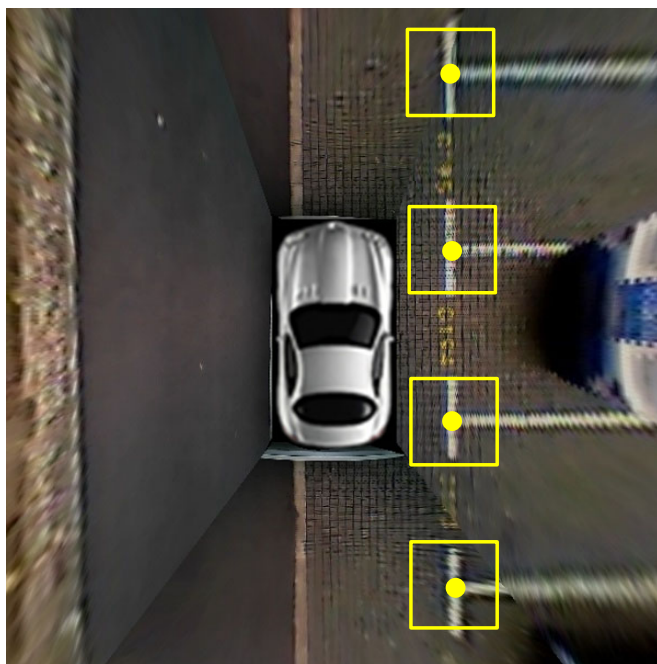



DeepPS: A DCNN-based Approach

- Marking-point detection by using a DCNN-based framework
 - We adopt YoloV2 as the detection framework
 - Manually mark the positions of marking-points and define regions with fixed size centered at marking-points as “marking-point patterns”
 - To make the detector rotation-invariant, we rotate the training images (and the associated labeling information) to augment the training dataset

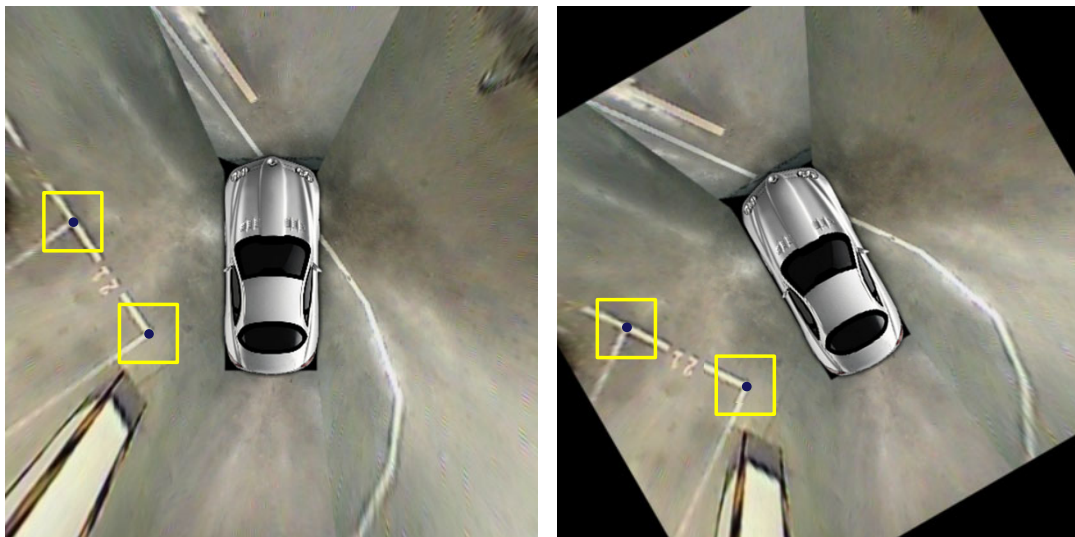



DeepPS: A DCNN-based Approach

- Given two marking points A and B, classify the local pattern formed by A and B for two purposes
 - Judge whether “AB” is a valid entrance-line
 - If it is, decide the type of this entrance-line

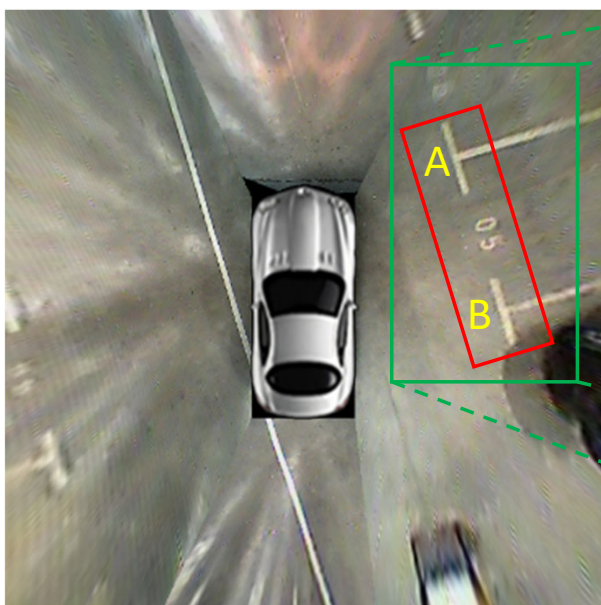

Local pattern formed by A and B
(48*192)

size normalized



DeepPS: A DCNN-based Approach

- Given two marking points A and B, classify the local pattern formed by A and B for two purposes
 - Judge whether “AB” is a valid entrance-line
 - If it is, decide the type of this entrance-line

We define 7 types of local patterns formed by two marking-points

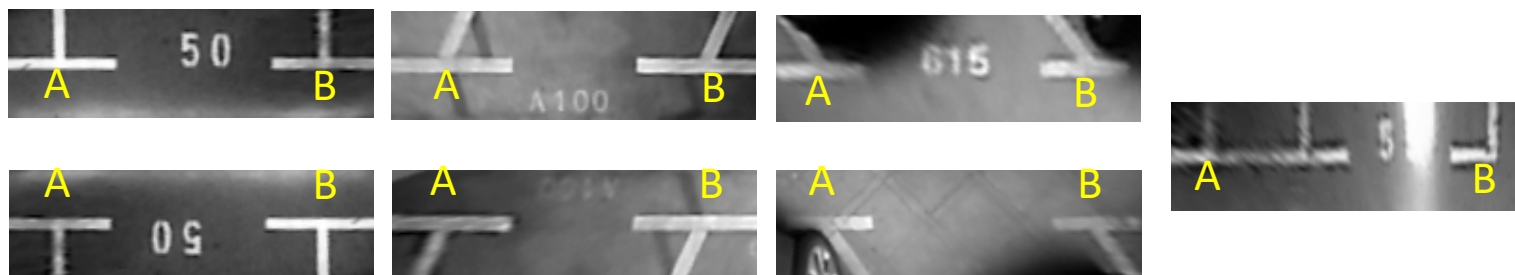

Typical samples of 7 types of local patterns



DeepPS: A DCNN-based Approach

- To solve the local pattern classification problem, we design a DCNN model which is a simplified version of AlexNet

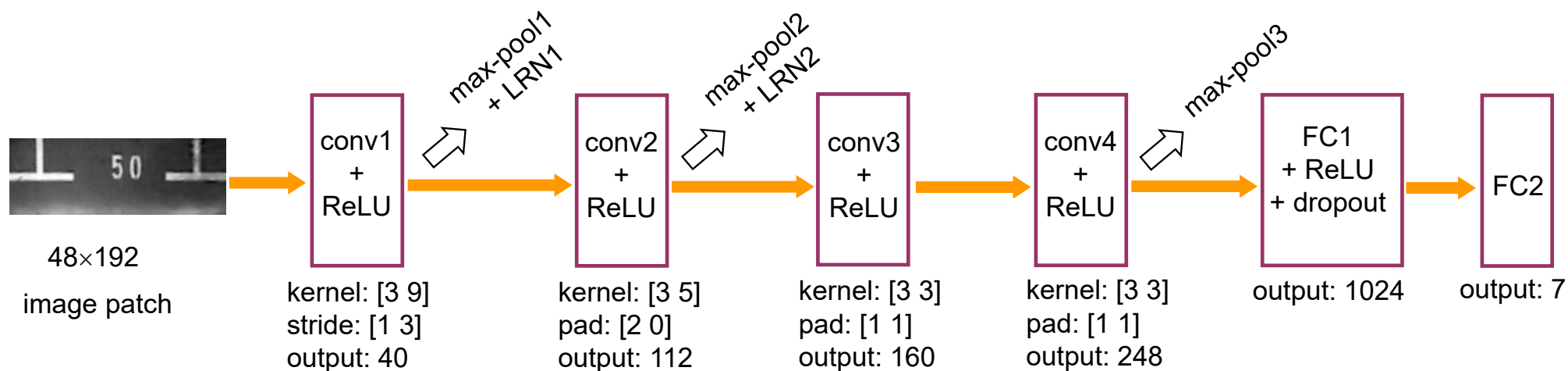

- Samples for slant parking-slots were quite rare, we use SMOTE^[1] strategy to create more virtual samples

[1] N.V. Chawla *et al.*, SMOTE: Synthetic Minority Over-sampling Technique, J. Artificial Intelligence Research 16: 321-357, 2002



DeepPS: A DCNN-based Approach

- For a slant parking-slot, how to obtain the angle between its entrance-line and its separating lines?



Prepare a set of templates $\{T_{\theta_j}\}$ having different angles



Extract the two patches I_A and I_B around A and B after the direction is normalized



$$\alpha = \arg \max_{\theta_j} \left\{ I_A * T_{\theta_j} + I_B * T_{\theta_j} \right\}$$



数据集

- We collected and labeled a large-scale dataset
 - It covers vertical ones, parallel ones, and slant ones
 - Typical illumination conditions were considered
 - Various road textures were included
 - 9827 training images
 - 2338 test images
- Test set is separated into several subsets

Subset Name	Number of image samples
indoor parking lot	226
outdoor normal daylight	546
outdoor rainy	244
outdoor shadow	1127
outdoor street light	147
outdoor slanted	48



停车位检测准确性

- Precision-Recall rates of different parking-slot detection methods

method	precision	recall
Jung <i>et al.</i> 's method	98.38%	52.39%
Wang <i>et al.</i> 's method	98.27%	56.16%
Hamada <i>et al.</i> 's method	98.29%	60.41%
Suhr&Jung's method	98.38%	70.96%
PSD_L	98.55%	84.64%
DeepPS	99.67%	98.76%



停车位检测准确性

- Precision-Recall rates of two best performing methods on subsets

subset	PSD_L (precision, recall)	DeepPS (precision, recall)
indoor-parking lot	(99.34%, 87.46%)	(100%, 97.67%)
outdoor-normal daylight	(99.44%, 91.65%)	(99.61%, 99.23%)
outdoor-rainy	(98.68%, 87.72%)	(100%, 99.42%)
outdoor-shadow	(97.52%, 73.67%)	(99.86%, 99.14%)
outdoor-street light	(98.92%, 92.00%)	(100%, 100%)
outdoor-slanted	(93.15%, 83.95%)	(96.15%, 92.59%)



演示视频

基于视觉的 停车位检测

同济大学软件学院
计算视觉课题组

张林 李曦媛 黄君豪 李林申

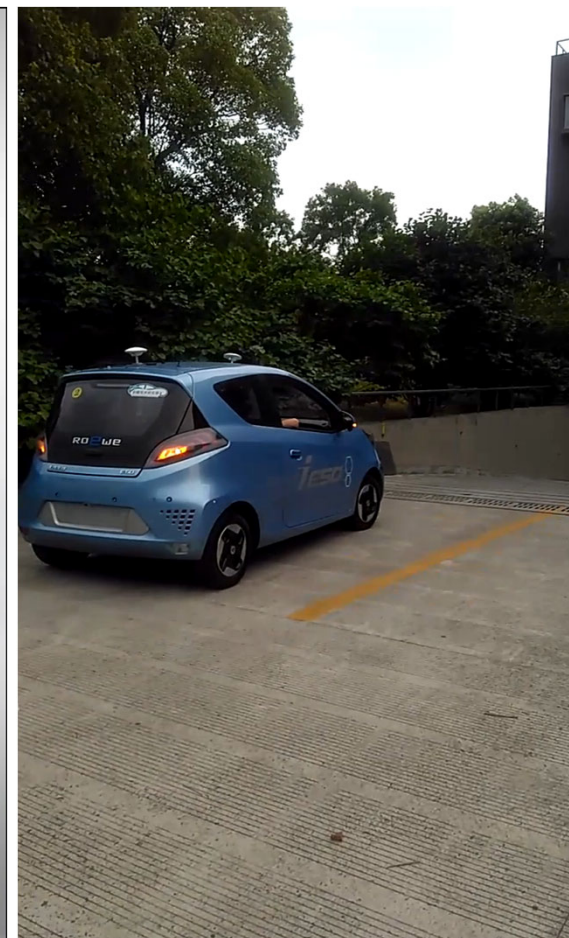



提纲

- 背景概述
- 环视系统离线标定与在线位姿修正
- 停车位检测与定位
- **VIS_{SLAM}: 面向室内自主泊车任务的SLAM系统**
- 总结与展望



SLAM系统中的数据融合方式

- 松耦合：利用各类传感器数据分别对系统状态进行估计，然后对估计结果进行融合，获得系统位姿，并构建场景地图
- 紧耦合：将所有传感器数据合并在一起对系统状态进行优化，获得系统位姿，并构建场景地图

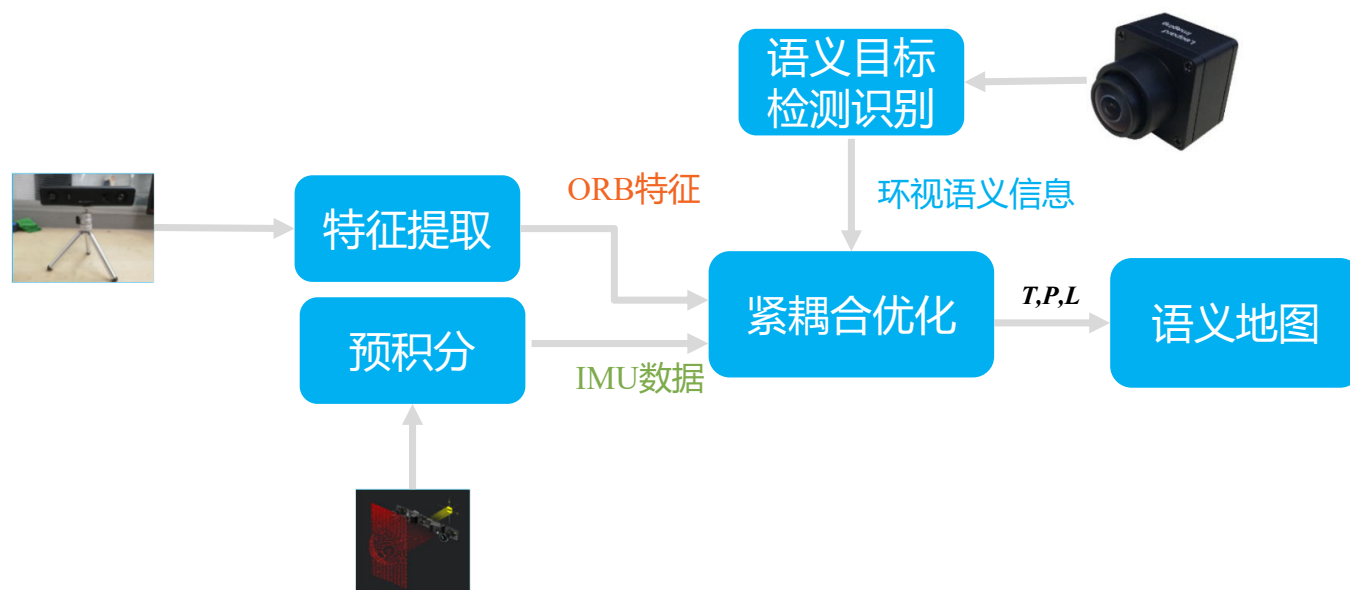

VIS_{SLAM} 数据融合方式



VIS_{SLAM}: 面向室内自主泊车任务的SLAM系统

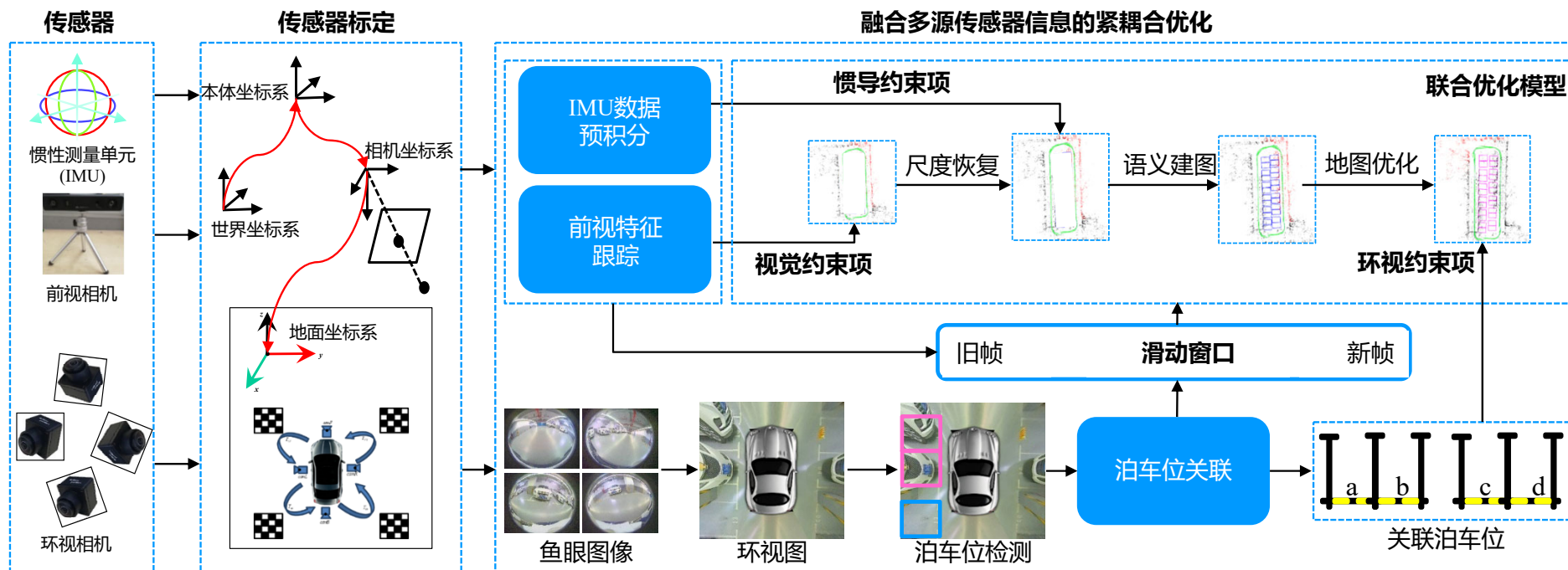

- IMU数据和视频帧依照时序信息关联，提供帧间运动约束
- 前视相机跟踪几何特征，提供视觉约束
- 环视相机系统提取地面上的语义信息，提供环视语义约束



传感器标定

- 相机的内参标定
 - 张正友标定法
- 环视相机系统的外参标定
 - 标定场
 - 标定板
- 前视相机的外参标定
 - 和环视相机系统的外参标定同步进行
 - PnP求解地面坐标系和前视坐标系的关系
- 视觉-IMU标定
 - Allan方差法确定IMU参数
 - 借助开源工具：Kalibr



融合多源传感器信息的紧耦合优化

观测数据

环视语义特征: O

前视特征点: Z

IMU数据: M

系统状态

相机位姿: T

环视语义地标的位置: L

地图点的位置: P

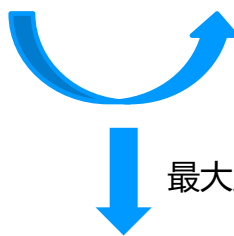

最大后验概率

$$\{L, T, P\}^* = \operatorname{argmax} p(L, T, P | O, Z, M)$$

贝叶斯公式

$$p(L, T, P | O, Z, M) \propto p(L, T, P) p(O, Z, M | L, T, P)$$

先验概率

观测数据

似然概率

- 先验概率通过一定变形, 可以转化为仅和系统状态自身相关的约束项
- 似然概率通过一定变形, 可以转化为包含观测数据的系统状态之间的约束项



融合多源传感器信息的紧耦合优化

观测数据

环视语义特征: O

前视特征点: Z

IMU数据: M

系统状态

相机位姿: T

环视语义地标的位置: L

地图点的位置: P



$$p(L, T, P)p(O, Z, M|L, T, P)$$

$$= p(L)p(T)p(P)p(O|L, T, P)p(Z|L, T, P)p(M|L, T, P)$$

$$= p(L)p(T)p(P)p(O|L, T)p(Z|T, P)p(M|T)$$

✓ 去除无关条件变量

- ✓ 系统状态之间相互独立
- ✓ 三类观测数据分别来自不同的传感器

上述公式可以转化成: 环视语义约束、视觉约束和惯导约束:

$$\{L, T, P\}^* = \arg \min_{T, L, P} E_S + E_V + E_I + C$$



定性结果

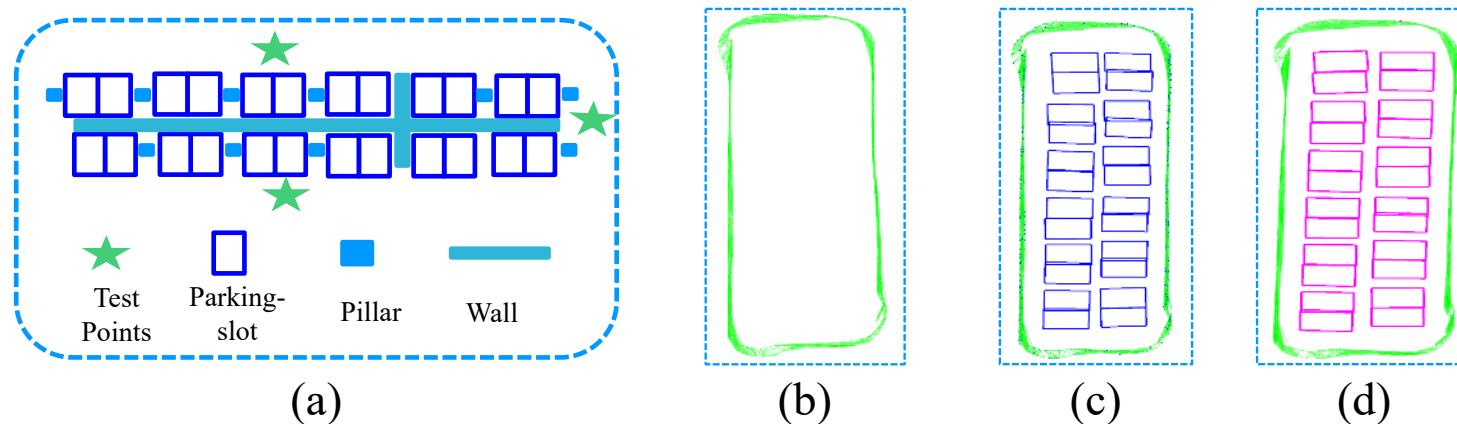

- ✓ 图(a)是同济大学地下车库的实际场景，该车库的每一排由12个泊车位组成，每两个泊车位彼此相邻为一组
- ✓ 图(b)是通过VI-SLAM系统构建的车库场景地图，其中只有3d点，没有语义信息，不适合室内泊车
- ✓ 在图(c)中，由于IMU恢复尺度很难绝对精确，地图的整体尺度偏小；另一方面，每组泊车位存在一定重合，这是定位误差、环视图误差和泊车位的检测误差共同导致的
- ✓ 在图(d)中，经过泊车位辅助优化后，建图结果更准确：首先整体尺度更为合理，每组泊车位之间的距离和两排泊车位之间的距离更符合真实场景环境的空间分布；此外，经过优化后，每组内的两个相邻泊车位之间基本正常贴合，不存在明显重合区域



定位精度：回环误差

- SLAM常用的精度评价指标包括相对位姿误差，绝对轨迹误差等
 - 依赖于真实路线的获取
- 回环误差：
 - 通过预先选择测试点，读取车辆重新访问测试点的坐标来评价定位精度

Point	X	Y	Z	ΔX	ΔY	ΔZ	ΔD
No.1	-3.61	-0.83	15.77	0.01	0.03	-0.04	0.051
No.2	-3.60	-0.82	15.70	0	0.02	0.03	0.037
No.3	-3.62	-0.83	15.75	0.02	0.03	-0.02	0.041
Ref.	-3.60	-0.80	15.73	0.022	0.041	0.054	0.075
Point	X	Y	Z	ΔX	ΔY	ΔZ	ΔD
No.1	-16.73	-1.77	35.08	-0.06	-0.01	-0.03	0.068
No.2	-16.78	-1.77	35.07	-0.01	-0.01	-0.02	0.024
No.3	-16.84	-1.77	35.03	0.05	-0.01	0.02	0.055
Ref.	-16.79	-1.78	35.05	0.079	0.017	0.041	0.091
Point	X	Y	Z	ΔX	ΔY	ΔZ	ΔD
X(m)	-17.06	-0.45	10.25	-0.01	0	0.02	0.022
Y(m)	-17.07	-0.45	10.31	0	0	-0.04	0.04
Z(m)	-17.06	-0.45	10.28	-0.01	0	-0.01	0.014
Ref.	-17.07	-0.45	10.2	0.014	0	0.046	0.048

- 首先由人手动驾驶车辆，初始化系统，构建停车场地图，待地图稳定后（一般需要环绕三圈以上），即可进行精度评测
- 第一圈由人手动驾驶车辆，在测试点处记录当前坐标，这个坐标即为参考坐标
- 车辆如果不具备自动驾驶功能，之后每一圈由人工驾驶，尽量精确的停靠在测试点上并记录位置
- 回环误差在10cm之内



建图精度：相邻停车位距离

- 由于地下车库的特殊场景，相邻停车位入口线的内侧点是重合的，所以我们可以通过计算相邻停车位的距离来衡量建图的精度

Parking Slot	1	2	3	4	5	6	7	8	9	10	11	12	Mean	Std
Before	0.80	0.11	0.32	0.23	0.098	0.029	0.21	0	0.20	0.27	0.25	0.19	0.23	0.20
After	0.18	0.18	0.074	0.073	0.096	0.060	0.11	0.29	0.077	0.060	0.073	0.21	0.12	0.072

- 由上面的表格可以看到，利用停车位辅助优化后，相邻停车位之间的距离明显下降，一定程度上证明了建图准确性的提升



视频展示

First row of parking-slots

- ① Xuan Shao, Lin Zhang*, Tianjun Zhang, Ying Shen, Hongyu Li, and Yicong Zhou, "A Tightly-coupled Semantic SLAM System with Visual, Inertial and Surround-view Sensors for Autonomous Indoor Parking", in Proc. ACM Int'l Conf. Multimedia, 2020
- ② Xuan Shao, Lin Zhang*, Tianjun Zhang, Ying Shen, and Yicong Zhou, MOFIS_{SLAM}: A Multi-Object Semantic SLAM System with Front-view, Inertial and Surround-view Sensors for Indoor Parking, *IEEE Trans. Circuits and Systems for Video Technology*, vol. 32, no. 7, pp. 4788-4803, 2022



提纲

- 背景概述
- 环视系统离线标定与在线位姿修正
- 停车位检测与定位
- VIS_{SLAM}: 面向室内自主泊车任务的SLAM系统
- 总结



总结

环视系统离线标定

- 标定板
- 标定场

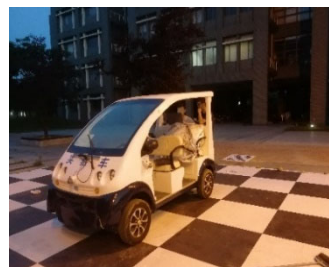
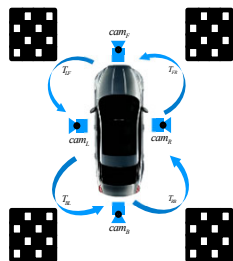

环视系统在线位姿修正

- 几何域/光度域

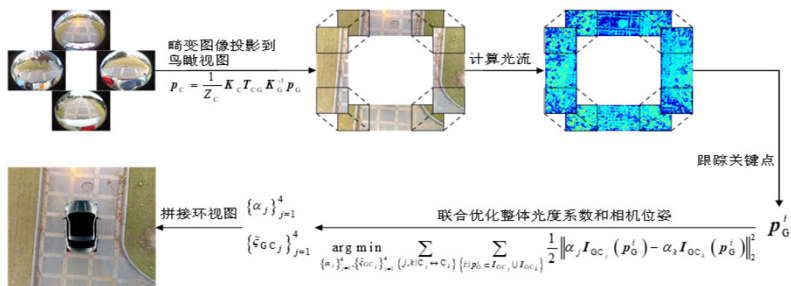

泊车位检测

- 基于视觉的泊车位检测算法
- 大规模泊车位图像数据集

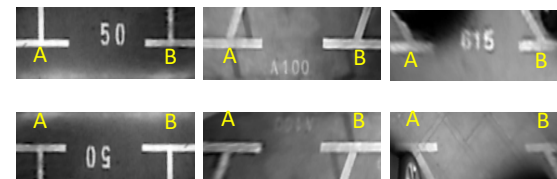
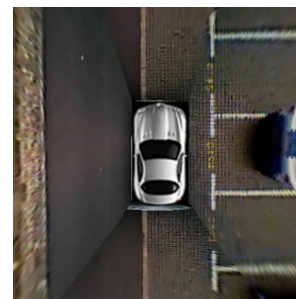

融合泊车位信息的紧耦合SLAM系统

- 环视语义约束项
- 视觉约束项
- IMU约束项

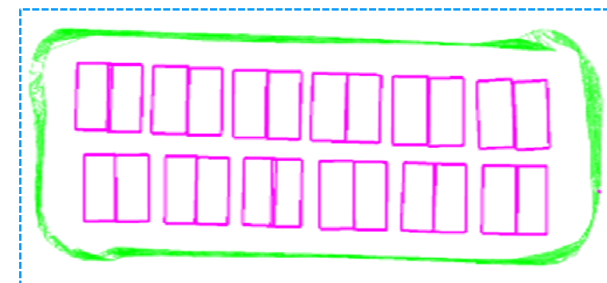



相关论文

- ① Tianjun Zhang, Lin Zhang*, Yang Chen, and Yicong Zhou, CVIDS: A collaborative localization and dense mapping framework for multi-agent based visual-inertial SLAM, *IEEE Trans. Image Processing*, vol. 31, pp. 6562-6576, 2022
- ② Xuan Shao, Lin Zhang*, Tianjun Zhang, Ying Shen, and Yicong Zhou, MOFIS_{SLAM}: A Multi-Object Semantic SLAM System with Front-view, Inertial and Surround-view Sensors for Indoor Parking, *IEEE Trans. Circuits and Systems for Video Technology*, vol. 32, no. 7, pp. 4788-4803, 2022
- ③ Tianjun Zhang, Nlong Zhao, Ying Shen, Xuan Shao, Lin Zhang*, and Yicong Zhou, ROECS: A Robust Semi-direct Pipeline Towards Online Extrinsic Correction of the Surround-view System, in: *Proc. ACM Int'l Conf. Multimedia*, 2021
- ④ Xuan Shao, Lin Zhang*, Tianjun Zhang, Ying Shen, Hongyu Li, and Yicong Zhou, A Tightly-coupled Semantic SLAM System with Visual, Inertial and Surround-view Sensors for Autonomous Indoor Parking, in: *Proc. ACM Int'l Conf. Multimedia*, 2020
- ⑤ Xiao Liu, Lin Zhang*, Ying Shen, Shaoming Zhang, and Shengjie Zhao, Online Camera Pose Optimization for the Surround-view System, in *Proc. ACM Int'l Conf. Multimedia*, 2019
- ⑥ Lin Zhang et al., Vision-based parking-slot detection: A DCNN-based approach and a large-scale benchmark dataset, *IEEE Trans. Image Processing*, vol. 27, no. 11, pp. 5350-5364, 2018



敬请批评指正!